

Process Fluid & Pump Filtration

ASC Filters "Auto Self Cleaning"



The Tally **ASC Filter System** uses the patented technology of the VAF V-Series™ automatic self-cleaning screen filters. The filters can be used wherever water flows and can remove suspended solids from 1500 to 10 micron. Individual filters and pre-assembled filtration systems are used in applications for Pre-Filtration of membrane, UV and other micro filtration technologies, as well as applications for industrial water reuse, SWD, fluid transfer, truck offloading, cooling towers, seawater, river intake water, well water, irrigation and many more.

The V-Series filter bodies are manufactured in 316L stainless steel and are competitively priced. The stainless steel bodies also come with a 5-year warranty against body leaks of any kind. The patented Bi-directional Hydrodynamic Drive (BHD) design DOES NOT require electric motors, limit switches, gearboxes, or hydraulic pistons, thereby eliminating external shafts and seals. The cleaning cycle takes less than 15 seconds and does not interrupt the filtration process.

SYSTEM FEATURES:

- Stainless, welded long radius 90's sized to the units inlet and outlet with the customer required connection flange for inlet, outlet and flush line.
- Optional 2" motor valve and VAF MicroFlush Controller
- Sizeable filtration and flow from 10 to 1500 micron at rates of 30 to 10,000 GPM.
- 6" channel, rigid oilfield type skid, decked with uprights and filter clamps with lifting eyes.

DSS Filters "Dual Simplex Strainer"



The Tally **DSS Filter System** utilizes two continuous flow simplex strainer baskets in unison, a piping manifold and isolation valves that are used in continuous flow pumping or filtration applications where the process cannot be shut down for cleaning. These applications include suction or inlet placement for hydraulic lift systems, SWD pumps, fluid transfer, commercial disposal facilities for pre injection and offloading, post well head filtration for "dirty wells" and much more. The filter pots can be cleaned out "on the fly" by isolating a single pot while the other pot is in use. By providing greater screen areas than a Y-strainer, with a simplex pot you optimize the total open area and minimize Potential pressure loss through the baskets.

Tally offers the DSS Filter System in carbon steel and stainless material with pipe sizing from 2" up to 6". Available in ANSI pressure ratings/flange sizes from 150 to 600. Filter baskets are available with screen sizes from 400 mesh (37 micron) up to 1/4" holes and all manufactured in SS material.

SYSTEM FEATURES:

- Differential pressure gauge plumbed to the inlet and outlet side of the filter with 3/8" SS tubing.
- 4" 0-300 Liquid filled inlet pressure gauge
- Two multiport 1/2" 10K needle valves for chemical injection and airbleed.
- Customer selected paint specs & color with hydro/xray reports.

Technical Specifications

ASC Filters "Auto Self Cleaning"

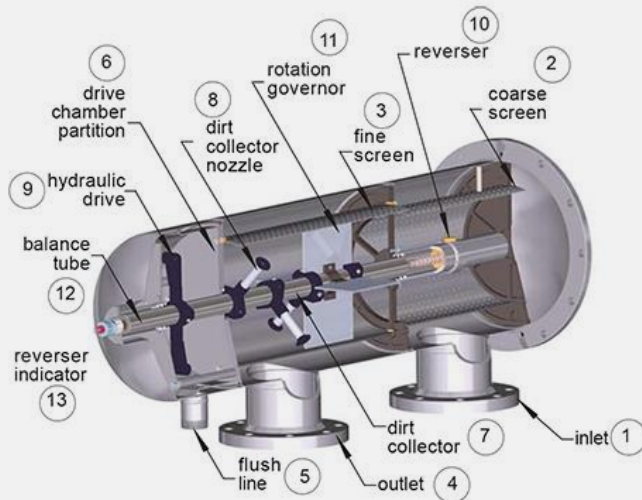

GENERAL SPECIFICATIONS:

- Bi-directional Hydrodynamic Drive
- Max Pressure: 10 bar (150 psi)
- Min Pressure: 2 bar (30 psi)
- Max Temp: 80° C (176° F)
- Flush Cycle: 12 to 15 seconds
- Flow Range per Filter: 7 to 2,274 m³/hr (30 to 10,000 gpm)
- Flange Sizes: 3" to 40"
- Screen Options: 10 to 1500 Micron on all models
- Manifold multiple units to increase flow ranges

MATERIALS:

- Filter Body – 316L standard; Super Duplex & Duplex SS for corrosive water
- Screens – 316L SS Weave-wire
- Seals – Nitrile, Viton, Silicone, EPDM
- Options:
 - Pressure vessel ASME, Section VIII, Div 1
 - Carbon steel, epoxy coated bodies are available on request on some models.

DSS Filters "Dual Simplex Strainer"



GENERAL SPECIFICATIONS:

- Flange sizes: 3" to 6" standard, other sizes may be requested.
- Basket options: 37 to 6350 Microns (400 mesh to 1/4" perforations).
- Butterfly isolation valves on ANSI 150 models
- Flanged ball valve on models over ANSI 150
- Flow rates: 0-2000 GPM depending on pipe size.

MATERIALS:

- Piping: SCH 40 ASTM A126, Grade WCB
- Flange(s): ASTM A105 Forged carbon steel
- Filter body:
 - Low pressure: cast iron ASTM A126, grade WCB
 - High Pressure: carbon steel ASTM A126, class B
 - Other materials such as stainless or duplex may be requested.
- Screens – 304 SS
- Seals – Buna-N 200F Max
- Gaskets – Spiral wound stainless steel
- Studs and nuts – ASTM 193 Grade B7

TALLY ENERGY SERVICES

14345 Northwest Fwy
Houston, Texas 77040

832-530-4880
info@tallyenergy.com

tallyenergy.com